

2018 - Late Model Rules

AREAS HIGHLIGHTED IN RED ARE CHANGES FOR THIS SEASON

Variations from any specification or rule must be approved by the speedway tech officials.

Minimum Age Requirements:

All drivers must meet minimum age requirements to compete at Selinsgrove Speedway. All drivers under the age of 18 must have a parent/guardian consent form on file in the speedway office before competing. Competing/Driving at Selinsgrove Speedway for the purpose of age restriction is defined as anytime the race vehicles wheels are turning, regardless of whether the vehicle is under it's own power or not. Birth Certificate or other proof of age may be required. Minimum age restrictions for competing/driving in the Super Late Model division is 16 years of age.

Exceptions – Exceptions to Selinsgrove Speedway age limits will only be granted to drivers holding a license/membership in a sanctioning body (ie..United Racing Club, Empire Super Sprints, World of Outlaws, etc.), provided said driver meets the minimum age requirements for that sanctioning body. The exception is only granted for events that the sanctioning body where the driver holds a license/membership is sponsoring or co-promoting/sanctioning at Selinsgrove Speedway.

Chassis/Frame

The wheel base minimum will be 103"-inches with a maximum wheelbase of 105"-inches.

All frames must be fabricated from magnetic steel with a minimum of 2"-inches x 2"-inches or approved rectangular magnetic steel with a minimum material thickness of .083"-inches.

A minimum of 1.75" Outside Diameter magnetic steel tubing, 4130 Chrome Moly or DOM with a minimum material thickness of .083"-inches, will be permitted for frames that are fabricated from round tubing.

Rear bumpers that are stubbed may only extend a maximum of 8"-inches beyond the frame. Any stubbed rear bumper that extends further than the maximum of 8"-inches must be formed and directed 8"-inches toward the front of the car.

External rub rails will not be permitted.

All cars must be equipped with a tow hook and/or strap for the purpose of towing.

All battery supports and/or mounts must be secure and braced in two (2) horizontal positions and one (1) vertical position.

Any frame built on or after January 1st, 2006, must have the builder's unique serial number plate prominently attached to the left side roll cage upright. The plate must be welded in place. All characters on the plate must be a minimum of ½"-inch in height and the serial number must not exceed 8 characters.

Body:

(Refer to diagrams 1 - 5 attached)

Overall Appearance:

The car must be neat in appearance and must display the car number on the front nose and the rear fuel cell. The minimum height for the number will be 6"-inches.

The car must have legible numbers on each side and on the roof a minimum of 18"-inches high.

The driver's last name must be placed in legible letters on both doors or the rocker panels.

General Body:

The nosepiece must match the body style of the make and manufacturer of the car and be the same as the make and manufacturer of the motor (GM, Ford, Mopar).

All cars must have a minimum half-inch (1/2") and a maximum of one (1) -inch radius at the top of fenders, doors and quarter panels. Sharp edge(s) will not be permitted.

The floor boards and firewall must completely cover the driver's area with no openings.

Fins and/or lips of any-type will not be permitted anywhere along the entire length of the car.

The body line must be a smooth even line from front to rear.

Wedge shape cars and/or body styles will not be permitted.

"Belly pans" or any type of enclosure on the bottom of the car will not be permitted. A skid plate to protect the oil pan is permitted. A maximum 1/8" skid plate will be permitted.

Wings and/or tunnels and/or any type of air deflection device will not be permitted underneath the body and/or chassis of the car.

A maximum of one (1) stone deflector, for rear mounted oil pumps, oil filters, and for the main oil tank will be permitted. The deflector may be made of steel, aluminum, or heavy gauge wire. The cover may only be mounted near the unit it is designed to protect with a maximum size of 18" x18" and only mounted from the upper right frame rail to the lower right frame rail.

Panels of any type under the rear deck running from the front to the rear of the car will not be permitted.

Bodies that are non-approved will be assessed a weight penalty. The minimum weight penalty will be as follows; 25 lbs per inch of the infraction.

Any style air cleaner scoop used must be positioned in front of/or around the air cleaner and must not exceed 1"-inch in height above any part of the air cleaner. Any type of flange and/or air deflection device and/or fin that is de-signed to direct airflow will not be permitted.

Cockpit adjustable components with the exception of brake bias adjusters will not be permitted. Adjusters of any-type, including but not limited to adjustable shocks, hydraulic or pneumatic weight jacks, trackers, ignition boxes or similar adjustable components will not be permitted inside the cockpit of the car or within reach of the seated driver.

The top edge, measured from the ground, of the rear quarter, door and front fender to the point where the fender flare attaches must be a straight line, within one inch on both sides of the car

Nosepiece:

Only approved nosepieces will be permitted. A list of approved manufactures and part numbers follows:

1. Dominator – The Official Nose of DIRTcar
2. MD3 - Performance Bodies
3. ARP- Air Speed Nose
4. Five-Star MD3 type
5. Performance Bodies/Five Star MD3 2015
6. Performance Bodies/Five Star 2016 Evolution

Approved nose assemblies must be installed per the manufactures instructions. All nose assemblies must meet the maximum/minimum dimensions, shall maintain manufacture appearance and not be altered.

Front nose assemblies, not meeting the maximum/minimum dimensions, at the series discretion, may be permitted to compete as a “non conforming” nose with a minimum of 50 additional pounds mounted in front of the motor plate. At series discretion, degree on non-compliance may require additional weight and/or placement of penalty weight in front of radiator.

All nosepieces must be made of molded type material.

Nose filler panel shall be flat across to entire surface, dishing or raising prohibited.

Two piece noses must be positively fastened together in the center. Spacers added to gain width will not be permitted.

The nosepiece must be mounted in a manner that does not alter its original shape.

The nose shall remain flat above the nose lip/wicker bill. Alterations and/ or additions may not be made to this area other than cooling holes will be permitted.

The nosepiece can extend a maximum of fifty-three inches (53") from the center of the front hub to the farthest point extending forward.

The nosepiece must display a headlight decal package. A one-race grace period, running contrasting color tape in the shape of a headlight will be permitted.

A maximum of three (3) two inch holes may be drilled into the nose for the sole purpose of air flow for engine cooling purposes. No ducts of any type will be allowed.

Roof:

The roof length from front-to-back must be a minimum of 44"-inches with a maximum of 54" inches.

The roof width from side-to-side must be a minimum of 48"-inches to a maximum of 52"-inches.

The roof must be stock appearing and be mounted level to the body.

The minimum height of the roof will be 45"-inches with a maximum height of 48"-inches. The roof will have a maximum rake of 3"-inches.

The roof must be mounted parallel to the body and near the center of the car as viewed from the front of the car. The entire rear edge of the roof, when measured from the bottom of the roof to the

top of the interior decking, shall maintain the same height measurement across the entire width of the roof.

A maximum 1-1/2" roll, turned downward will be permitted along the front edge of the roof. A maximum 1"-inch roll, turned downward, will be permitted along the rear edge of the roof. These modifications will be permitted to improve the strength of the roof. Any other modifications to the roof will not be permitted.

Flat and/or odd shaped roofs will not be permitted. Bellied and hollowed roofs will not be permitted. Any sun/antiglare shields may not exceed a 4" drop from the top roof line, and must hinge for easy exiting.

A maximum of two (2) roof edge bead rolls of a maximum height of 1/2" inch the length of the roof will be permitted.

The roof posts and spoiler support(s) may not overlap.

Only single plated roofs will be permitted.

The maximum thickness of the roof at any point will be 1/2"-inch.

The roll cage and associated frame members above the interior panels (decking) must remain open. Enclosures will not be permitted.

Roof Supports and Window Side Panels:

All roof side panels must extend to the edge of the body.

The roof side panel window size must be a minimum of 10"-inches x 15"-inches and must match drawing number -4- side view. A maximum crown of two (2) inches will be permitted, measured from the center of a common tangent point on either side of the crown.

The side window area may be covered with clear Lexan and/or equivalent type material, be cut out and/or represented by a decal. Both roof support openings must be covered and/or both must be left open. The left and right side openings must be the same size with a tolerance of one (1) inch.

The left and right side window panels must match.

A maximum bow of two (2)"-inches outward on the window side panels as viewed from behind will be permitted. See drawing -4-.

The front roof supports up to 2"-inches in width must extend forward to the rear of the hood. Lips and/or fins will not be permitted.

Front Fenders, Fender Flares and Hood:

The hood and the front fenders must be level and flat from the left to the right side of the car.

The outside edges of the hood and/or the fender must remain inside the overall bodyline.

The front fender may be a maximum of 37"-inches in height, measured vertically from the ground to the top of the fender behind the front tires.

The front fender flares must be made of plastic and must not alter the original shape of the nose piece.

The front fender flares must not extend beyond the front tires more than 1"-inch per side to a maximum width, edge-to-edge, of 90"-inches in width with the wheels pointed straight.

The front fender flares must be flat across the entire width of the car. Front fender flares shall not extend, bubble or rise more than a maximum of four inches (4") at any point of the front fenders and/or hood.

The front fender flares must have collapsible supports.

Doors:

The door-to-door measurement must not exceed 76"-inches in width at the top of the doors.

The door-to-door measurement must not exceed 82"-inches overall width when measured at the bottom of the doors in the center of the car.

The doors must not exceed 37"-inches in height when measured from the ground to the top of the door.

The measurement from the ground to the top of the door, on both sides of the car – right door and left door, must measure within one inch (1") variance.

The door sides may not break inward from the top 76"-inches and bottom 82"-inch measurements. Hollow and/or bellied doors will not be permitted.

The minimum ground clearance will be 3"-inches.

Quarter Panels:

The maximum distance from the center of the rear hub to the top quarter of the panel is fifty two (52")-inches. See drawing #2 1.7A.

The quarter panels must not exceed 76"-inches in width at any point as measured at the top of the panels.

The rear deck must taper in a symmetrical manner from the center of the rear hub to the rear spoiler with a minimum width of 72 inches and a maximum width of 76 inches.

The maximum width for the quarter panels measured from outside-to outside measured 19"-inches from the ground and/or at the bottom of the quarter panel will be 86"-inches.

Any breaks and/or bends formed in the sides of the quarter panel that move the panel toward the center of the car will not be permitted. Hollow and/or bellied panels will not be permitted.

The maximum distance from the center of the rear hub to the rear trailing edge of the quarter panel will be 48"-inches. See drawing #2 1.7A.

The maximum height from the ground to the top of the rear deck at the top of the rear quarter panel is 38"-inches.

A minimum of 2"-inches of tire clearance between the tire and the body will be required.

Skirting that extends behind rear quarter panel will not be permitted.

Spoilers and Spoiler Braces/Supports:

Only aluminum and/or Lexan and/or Lexan-type rear spoilers will be permitted.

The maximum overall height of the rear spoiler will be 8"-inches. The maximum width of the rear spoiler, including braces and/or supports is 72"-inches.

The rear spoiler must begin at the deck and extend 8"-inches from that point. Suspending the spoiler to create a wing-type device will not be permitted.

The rear spoiler must begin at the rear most point of the quarter panels.

Only three spoiler braces/supports will be permitted. The front edge of the spoiler brace/support must be in line with the spoiler.

The outside spoiler supports must not be mounted any-wider than the top of the quarter panel(s) and must be centered on the rear deck.

In the event that aluminum angle is used to brace the upper edge of the spoiler, the angle must not add to the height and/or length of the spoiler in any way.

Interior:

The interior of the cockpit must be a minimum of 11"-inches below the top of the roof and/or roll cage, measured perpendicular to the ground from the bottom of the roof to the cockpit deck. Roof rolls are not part of the measurement.

The side window opening(s) must be 15"-inches from the top of the door to the bottom of the roof.

Support bars that block the right window from the driver exiting the cockpit will not be permitted.

A single rock guard (Lexan screen) tapered back from the steering wheel to the height of 1"-inch in line with the driver's chest providing the 11"-inch minimum clearance is met at any point from the roll cage to the body and/ or rock guard.

If the interior deck drops the drop must begin at the rear of the engine plate with a maximum of 4"-inches and must not drop below 4"-inches at the rear of the hood. The start of the dropped interior must remain closed as a part of the fire wall. The entire width must be closed off with sheet metal.

The interior must gradually taper up to the quarter panel height and must be level for a minimum of 20" inches from the rear of the quarter panel deck..

Driver Compartment:

A full metal firewall fabricated from magnetic steel and/or aluminum must encompass the driver's compartment from front-to-rear, on both sides and floor boards.

The driver's seat must be a high back aluminum seat, designed specifically for racing, located on the left side of the car and mounted per the manufacturer's instructions securely to the frame.

The seat design should be one from a current manufacturer and/or recommended to include the full containment design. Installation of the full containment seat should follow the manufacturer's instructions.

All cars must be equipped with a quick-release type steering wheel.

The driver compartment must have a starting switch and/or button within reach of the driver.

A clearly labeled electrical on/off 'kill' switch within reach of the driver is recommended.

Mirrors of any-type will not be permitted.

Radios and/or electronic and/or data communication devices will not be permitted.

Any edge and/or sheet metal end in and around the driver compartment must be protected with trim and/or beading and rounded. Sharp and protruding edges will not be permitted.

A substantial rock guard with a minimum of three (3) additional roll bars must be mounted in front of the driver. The rock guard must be made from wire screen. Wind- shield screens must be a minimum of .090-inches and must be securely fastened.

A fully charged fire extinguisher meeting SFI 167.1 specifications with an activation push and/or pull knob within reach of the driver is recommended

Suspension:

Rear suspension designs and applications are constantly evolving. Although the intent of the rear suspension rules are an attempt to accommodate the majority of suspension and suspension component designs and applications currently being used in competition, the rules cannot be absolute. Any and all new designs or modifications to an existing suspension and/or suspension component must be communicated to and approved by the Series Director or Technical Inspector before being used in competition.

Rear suspension must utilize either coil or leaf springs.

Rear suspension configuration used on current and new chassis(s) must be the design commonly known as four (4) link. Older cars currently competing with other rear suspension designs will be allowed to compete until further notification.

Rear Suspension and Suspension Components:

Axle Housing, Rear Differential

The axle housing must be of the "closed tube" design utilizing "full floating" magnetic steel axle shafts.

The center section of the axle housing must be manufactured of either aluminum or magnesium.

Axle tubes must be one (1) piece. Axle tubes must be manufactured of aluminum or magnetic mild steel. Axle tubes manufactured of exotic, heavy materials will not be

permitted. The outside diameter of the axle tubes must not exceed three (3) inches. Axle tube internal inserts or external sleeves will not be permitted. The addition of any ballast weight to the axle housing will not be permitted.

Axle Housing Mounts

Only one (1) axle housing mount per side will be permitted

The only materials used to fabricate axle housing mounts (birdcages) that will be permitted is aluminum or magnetic mild steel. Axle housing mounts fabricated of exotic, heavy materials will not be permitted.

When fabricating axle housing mounts detail must be paid to functionality. The completed axle housing mounts, when comparing the right and the left side, must be as similar in design as possible.

Axle housing mounts may be a solid (welded) type or a floating type (birdcage) design.

The final assembled axle housing mount must be a one (1) piece mount. When a floating type mount (birdcage) is fabricated using two (2) pieces, the two (2) pieces must create a common one (1) piece pivot (barrel). The two (2) pieces must be fastened or welded together to prevent independent movement of the two (2) pieces. The axle housing mount must attach directly to the axle tube with clearance only to permit rotation of the entire mount. Fore, aft or vertical movement of the mount or the axle housing within the mount will not be permitted.

Rear Suspension Attaching (Radius) Rods

A maximum of two (2) attaching (radius) rods per side will be permitted.

The only materials used to fabricate attaching (radius) rods that will be permitted are magnetic steel or aluminum

Attaching (radius) rods may be solid or tubular material. The material may be round or hexagon in shape.

Spherical rod ends or steel clevises must be used at the end of each rod for pivoting, static length adjustment, and mounting. Bushings of any type will not be permitted.

The final assembled attaching (radius) rod must not have the capability to change length dynamically by any means or devices.

Spherical rod end sizes may be a minimum of a 5/8-inch rod end body with a 1/2 inch bearing to a maximum of a 3/4 inch rod end body with a 3/4 inch bearing.

In all applications, the correct size fastener must be used when mounting the spherical rod end to a bracket (example: 1/2 inch fastener must be used with a 1/2 inch bearing and mounting hole). Metal step spacers will be permitted to reduce the hole size of the spherical rod end bearing.

Attaching (radius) rods must mount directly to the frame suspension mount at the forward end and to the axle-housing mount at the rearward end.

All rear suspension fasteners must be magnetic steel with a minimum diameter of 1/2 inch. The use of grade 8 fasteners is highly recommended. All fasteners must be correctly sized

for the component and application of use.

When rear suspension assembly is completed, the attaching (radius) rods must have a minimum of eight (8) inches between the pivots at both the frame suspension mount and the rear axle-housing mount.

Rear Droop Limiter

One (1) droop-limited chain per side will be permitted.

The droop limiting chain may incorporate bump stops and/or springs.

The droop limiting chain must attach to a collar or bearing type mount on the rear axle tube and to the frame assembly directly above the lower mount. Chains to the rear axle mount (birdcage) will not be permitted.

Droop limiting chains must be mounted so that when taunt they are as close to vertical as possible.

Torque Control Devices

Lift arm assemblies and pull bars will be permitted.

Only one (1) torque control device may be used.

Lift arms must attach to the axle housing using a mounting configuration that prevents any movement between the lift arm and the rear axle housing. A gusset or brace bar to prohibit side-to-side flex will be permitted.

The forward end of the lift arm may use a spring over shock assembly (5th coil), a spring or bushing, and a limiting chain.

Pull bars may be adjustable on both ends; however, the adjustments must remain fixed during competition. Adjustors within reach of the driver will not be permitted

Rear Springs

Coil springs or leaf springs will be permitted.

Coil springs must be manufactured from magnetic steel. Leaf springs must be manufactured from either magnetic steel or approved composite material.

Spring preload adjustments for coil springs must be made using mechanical adjusting nuts on the shock body.

Spring preload adjustments for leaf springs must be made using a mechanical adjusting device such as an adjustable shackle or threaded rod type mount.

Other than spring dampening by the shock absorber, hydraulic, pneumatic, or electrically controlled adjusting devices, (static or dynamic) that affect spring preload or race car heights will not be permitted.

Brakes, Brake Components, Wheel Hub:

Brake calipers must be manufactured of aluminum.

The brake caliper including brake caliper pistons must be used as produced by the brake caliper manufacturer.

Brake rotors must be manufactured of magnetic or stainless steel.

Brake rotors must be used as produced by the brake rotor manufacturer.

Wheel hubs must be manufactured of aluminum or magnesium.

Wheel hubs must be used as produced by the wheel hub manufacturer.

The combined weight of the wheel hub, wheel bearings and seal, spindle nut and washers, brake rotor and attaching hardware, the axle cap and the wheel spacer must not exceed twenty-seven (27) pounds.

Suspension Miscellaneous:

All cars must be equipped with an operating four-wheel disc brake system.

Lift and/or pull bars will be permitted. A fifth link will be permitted. The lift and/or pull bar and/or fifth link must not have any mechanical and/or hydraulic and/or pump-type assistance.

Inerters and/or mass dampers on the vehicle suspension, including but not limited to devices that are stand-alone and/or those integral to the suspension shock absorbers will not be permitted.

All rear suspension radius rods, panhard bars and lift bar must be of a fix/solid design. Hydraulic cylinders, spring rods, bump rods, slider rods or shock type radius rods will not be allowed to locate rear end.

Maximum of one shock may be used on lift bar and two springs in addition to one 6th coil or braking spring.

Shock Absorbers:

All shock absorbers must be constructed of magnetic steel and/or aluminum.

Remote reservoirs will be permitted. Canister shocks are permitted.

All cars will have a maximum of 6 shocks allowed, one additional conventional-type "wrap-up" or "90-10" style shock located directly above rear end center section is permitted.

Only conventional type closed shock absorbers and/or approved shock absorbers will be permitted for competition. Only single shaft shock absorbers will be permitted and all shock absorbers must remain closed on one (1) end via conventional design.

1, 2, 3, or 4-way adjustable shocks are permitted provided they cannot be accessed by the driver, on track, during race events.

Electronically controlled shock adjustments by any means or method are not permitted.

"Through-rod" designs are not permitted.

Communication; hydraulically, electronically, magnetically, or otherwise, between any two or more shocks on a vehicle is strictly prohibited. This includes "cross-over" shocks.

Inerter style dampers, either mechanical or hydraulic, or other type of primarily acceleration sensitive damping device is not permitted.

Suspension Components/Springs:

Coil springs or leaf springs will be permitted.

Coil springs must be manufactured from magnetic steel.

Leaf springs must be manufactured from either magnetic steel or approved composite material.

Spring preload adjustments for coil springs must be made using mechanical adjusting nuts on the shock body.

Spring preload adjustments for leaf springs must be made using a mechanical adjusting device such as an adjustable shackle or threaded rod type mount.

Other than spring dampening by the shock absorber, hydraulic, pneumatic or electrically controlled adjusting devices (static or dynamic) that affect spring preload or race car heights will not be permitted.

Roll Cage:

All cars must have a roll cage fabricated from a minimum of 1-1/2" outside diameter with .065"-inch thick seamless magnetic steel tubing.

The side roll bars and/or door bars must extend into the door panels.

A minimum of three (3) bars must be utilized on the left side of the car in the door area.

Any of the bars that are utilized for the top portion of the roll cage, including, but not limited to the front and rear hoops, the top hoop and the uprights, must extend a minimum of 1"-inch above the driver's helmet.

All new frames and/or roll cages built on or after January 1st, 2006 an additional vertical side brace is required on the left side in vertical alignment with the steering wheel.

Wheel, Wheel Discs, Wheel Spacers:

Only aluminum wheels will be permitted.

Only approved wheel discs will be permitted.

It is recommended but not required to use wheel discs that are fastened to the wheel using a minimum of three (3), ¼ inch or 5/16 inch diameter magnetic steel hex head bolts.

Approved wheel discs may still be attached using steel Zues fasteners.

Only aluminum wheel spacers will be permitted. Wheel spacers must not be fastened to the wheel.

The combined weight of the wheel, wheel hardware, wheel disc and fasteners and tire must not exceed forty (40) pounds*. *The maximum combined weight in this rule is based upon current tire rules and may need to be adjusted in the event of an alternate tire*

The wheels must be mounted to the hubs utilizing lug nuts. "Knock off" and/or single type wheel mounting systems will not be permitted.

The maximum wheel width that will be permitted is 14"-inches.

The maximum front track width will be 90"-inches and the maximum rear track width will be 88"-inches, measured from the outside edge of the tire to the outside edge of the tire.

Wheel spacers will be permitted provided the track width(s) do not exceed their maximum dimension.

Engines:

Only conventional type V-8 engines with the cam in the block will be permitted. There will be no limit on the cubic inch displacement.

All engines must be based on a manufactured, factory design.

Aluminum or steel blocks will be permitted.

All engines must be normally aspirated with a single conventional-type four (4) barrel carburetor.

The engine must have an operating self-starting mechanism. Vehicles that require a 'push start' will not be permitted.

Only a single distributor or magneto will be permitted. Coil pack and/or engines that have individual ignition systems, electronic or mechanical for each cylinder will not be permitted.

A maximum of 25 ½"-inches from the center of the ball joint to the front of the motor plate/engine bell housing flange will be permitted.

Only two (2) valves and one (1) spark plug will be permitted per cylinder.

Transmission/Driveline and Driveline Components:

Direct drives systems of any-type will not be permitted.

The transmission must be bolted to the engine it must have forward and working reverse gear(s) and must be able to shift to forward or reverse with engine running.

All cars must be equipped with a working self-starter.

Driveshaft:

The driveshaft must be a minimum of 2"-inches in diameter. All drive shafts must be painted white.

Only one (1) drive shaft connected from the transmission to the center section of the rear end will be permitted.

A minimum of one (1) driveshaft hoop / sling must be fastened securely to the frame. It is recommended that two (2) driveshaft hoops / slings be used.

Rear End:

Any type of rear end differential / center section will be permitted.

Live-axle type rear ends will not be permitted.

Independent rear suspensions will not be permitted.

Floater-type wide-five hub assemblies will be the only hub assemblies permitted.

Fuel, Fuel Cells and Fuel System:

All cars must have fuel cells. **It is recommended they meet and/or exceed FT3 specifications.**

The fuel cell may not have a capacity of more than 35 gallons.

The fuel cell must be enclosed completely in a container that is a minimum thickness of 20-gauge magnetic steel and/or .060"-inch aluminum.

The entire container must be visible for ease of inspection.

The fuel cell must be mounted behind the rear axle between the rear tires, a minimum of 4"-inches ahead of the rear bumper. The bottom of the fuel cell must not be any lower than the bottom of the rear end/quick change housing.

The fuel cell must be mounted with a minimum of two (2) .125"-inch thick steel straps. The straps must cover the entire cell. Fuel cells that are mounted in a square tubing frame will be permitted.

The fuel pick up must be positioned on the top or right side of the fuel cell and be constructed of steel. The fuel pick up must have a check valve.

Only racing gasoline or alcohol will be permitted for competition. Nitrous oxide, nitro-methane and/or propylene oxide will not be permitted.

Only mechanical and/or belt driven fuel pumps will be permitted. Fuel injection system(s) and/or electrical fuel pumps and/or any type of pressurized fuel system will not be permitted.

Battery:

The battery must be securely mounted with positive fasteners and brackets.

The battery terminals must be insulated and the battery enclosed with a non-conductive material that will prevent contact with any part of the race car should the battery become dislodged from the battery mount.

One (1) mandatory battery disconnect switch must be installed on the rear deck, behind the driver seat, in a location that is easily accessible from outside the race car. The switch must be clearly

labeled with On/Off direction. The switch must be directly in-line with the NEGATIVE battery cable and be capable of completely disconnecting the NEGATIVE terminal of the battery from the race car. Negative or "ground" wiring connections must not be made anywhere from the battery negative terminal to the input side of the disconnect switch.

Exhaust:

The exhaust flow must be parallel to the ground. Exhaust systems that direct the flow toward the ground will not be permitted.

All exhaust systems/headers must end with a collector.

Traction Control Devices:

All electronic and/or computerized wheel spin and/or ignition retardation and/or acceleration limiting and/or traction control devices of any type will not be permitted.

Adjustable ping control devices, dial a chip controls, timing controls and/ or automated throttle controls will not be permitted.

Adjustable restrictor plates will not be permitted.

Remote control components of any-type will not be permitted.

Radios and/or devices for transmitting voice and/or data will not be permitted.

Data acquisition systems and/or electronic or digital timing devices will not be permitted.

Weight/Ballast Rule:

Total weight of car and driver may not be less than **2,300** pounds or more than 2,800pounds. No allowance given. Weigh-in to be after any event or qualifying. Weight to be measured as car comes off the track in the condition that it took the checkered flag. Any added weight must be securely fastened. Weight measured by Selinsgrove Speedway scales. Any car that completes a time trial or finishes in the top 3 of any heat, top 5 of any main event, or otherwise as directed by speedway officials, that does not go directly to the scales first before the car stops with the crew and/or at the trailer will be disqualified and scored last for that event. Track officials may request that you shut off the engine of your car while on the scale. Driver must remain still in the seat while car is being weighed. Any car that is deemed light will be reweighed a second time. The car in question will be rolled off the scale by hand, the scales will be reset and the car immediately rolled back onto the scale by hand. Cars will not be permitted to leave the on/off ramps of the scale between reweighs unless directed by track officials. Any car required to be weighed at the completion of any event that does not meet the minimum weight requirements will be disqualified and scored behind all other cars that were on the track at the end of the event. The number of cars required to be weighed for any event may be changed by track officials and teams will be notified.

Weights up to 50 lbs must be positively fastened by 2 ½-inch, minimum grade 5 bolts with a minimum of two (2) weight clamps. Threaded rods will not be permitted. All weights must be painted white and clearly labeled with the car number on it.

Any weight(s) must be securely attached to the frame below the body decking. Frame is defined as the steel welded structure only. Any part that moves or is not a fixed component to the steel frame structure may not be used for any weight attachment.

Any car that loses any weight/ballast during an event may be subject to a penalty.

Weights attached to the rear bumper and/or outside the frame will not be permitted.

Pellet-type and/or liquid-type weight/ballast will not be permitted.

Driver operated weight adjustment, 'weight jacking' devices will not be permitted.

TIRES:

Hoosier Racing Tire On All 4 Corners

FRONT:

28.5/11-15 Rib 1300 or harder

LEFT REAR:

28.5/11-15 Rib 1300 or harder

11/88-15 LCB 1300 or harder

RIGHT REAR:

29/11-15 1300 or harder

29/11W-15 1300 or harder

Drivers may continue to use the old numerical system tires of D15 or harder for all corners.

Right Rear, 29/11-15 1300 or Harder

Right Rear, 29/11-15 Rib 1300 or Harder

There is no regulation on how soft a tire can be.

ALL factory sidewall markings must remain intact and visible at all times.

NO grinding, buffing, altering, or attempts to alter any sidewall designations or markings is permitted. Tires found in violation or that are missing any information for any reason will be considered illegal.

Cars found to have an unapproved tire(s) or an illegal tire(s) will cause the car and driver to be disqualified.

If discovery is made during any race or time trial or during any post race or time trial technical inspection, the car and driver will be disqualified, scored last for that race or given no time for time trial. Both car and driver will also forfeit any and all championship points, awards and prize money for the individual event in which the infraction was found.

Radios/Transponders:

No radios (one way or two way) or other means of electronic communications between the driver and anyone other than track officials is permitted.

All drivers are required to use a receiver capable of receiving frequency 454.000 for one way communications from track officials.

Late Models are required to use transponders. Rental units are available from the speedway.

Transponders for Late Models should be mounted on the rear side of the engine mounting plate or to the engine compartment side of the firewall but can be no less than 80" from the center nose of the car. Shims can be used between the engine plate and mounting bracket to obtain this distance.

Transponders must be mounted in a vertical position pointing straight down and as close to the ground as possible. There cannot be any metal, carbon fiber or other material that would deflect or block the signal between the transponder and the ground.

Other than wiring used to connect direct powered units the transponder should not be mounted within 12" of any device that generates, transports or stores electric or magnetic energy (individual race cars may require a greater distance or shielding).

Transponders/brackets should be riveted, wire tied or clamped to the mounting point with additional wire ties, clamps or other securing devices encompassing the entire mounting point /bracket / transponder for additional security.

Speedway is not responsible for lost/damaged transponders. Damaged/Lost units rented from Speedway are the responsibility of renter.

It is each race teams responsibility to assure that the transponder they are using is mounted properly and in working condition at all times car is on track.

Changes in mounting location may only be approved by speedway electronic scoring technicians and only in the case of transponders not reading correctly. This shall only be approved if it is determined by speedway electronic scoring technicians that all other possibilities and scenarios to correct the situation have been exhausted.

Personal Safety Equipment:

General

Each competitor is solely responsible of for the effectiveness and proper installation, per the manufacturer's specifications, of personal safety equipment and determining it to be adequate for competition at every event. Each competitor is expected to investigate and educate themselves for continuing improvement regarding their own personal safety equipment.

Seat Belt/Restraint System

Each car will be equipped with minimum of an SFI 16.5 or SFI 16.1 approved restraint system, until the date of the belt expiration (two years from the date of manufacturer). Seat belt restraint systems shall be installed and used in accordance with manufacturer's instructions. *In any type of manufacturer's installation the fasteners should be magnetic steel unless using type of mount in which the seat belt wraps around the roll cage.*

Seat belt material should not be permitted to come in contact with any sharp or metal edge, including when the material passes through the seat.

Protective Clothing

All drivers will be required to wear a fire resistant driving uniform meeting minimum of the SFI 3.2A/5 specification and display a valid SFI 3.2A/5 label.

All drivers should wear fire resistant accessories including but not limited to; head sock, under garments, shoes, and socks. All drivers are required to wear fire resistant gloves. Shoes and

gloves will be required to meet minimum of the SFI 3.3 specifications and display a valid SFI 3.3 label.

Seats

Aluminum and/or carbon fiber-type seats will be permitted. It is recommended that aluminum seats have an FIA and/or SFI rating, any carbon-fiber-type, composite seats must meet the SFI Rating 39.2. All seats must be mounted to the frame as required by the seat and chassis manufacturer.

All areas surrounding the head should have padding.

A right side head restraint net and/or support are required. All head restraint nets should be equipped with quick release mechanisms.

Helmets

All drivers will be required to wear a full-face helmet with a minimum safety rating of FIA 8860-2004, FIA 8860-2010, Snell SA 2005, Snell SA 2010, Snell SAH 2010 and/or a valid SFI 31.1/2005 label.

It is strongly recommended that helmets should be fitted with the Eject™ helmet removal system.

Head and Neck restraints are strongly recommended. The head and neck restraint system must be mounted and connected to the helmet per the helmet manufacturer and head and neck manufacturer instructions.

Arm restraints are recommended and must be connected and used as instructed by the manufacturer.

RECOMMENDED Safety Equipment

Driver's side window net.

Sharp and/or protruding edges in and around the cockpit will not be permitted.

Windshield screens should be a minimum thickness of 0.090 inch and should be securely fastened to the roll cage.

A clearly marked electrical engine shut off switch within the reach of the driver.

A clearly marked fuel shut off valve within reach of the driver.

Only SFI flame retardant seat, roll bar, knee and steering pads and/or padding should be utilized.

Driveline U-Joint scatter shields are recommended.

All teams should have an easily accessible 2.5 gallon FFF fire extinguisher or its equivalent at the back of the team's transporter.

***Note - these rules are subject to change during the racing season. ***

The officials' interpretation of these rules is FINAL.

Variations from any specification or rule must be approved by the speedway tech officials.

All cars are subject to technical inspection at any time. Refusal to allow technical inspection may result in disqualification and loss of points and prize money for that event.

PROTESTING SPECIFIC COMPONENTS ON ANY RACE CAR:

Only a driver from that particular race may protest a component on another competitor's car. Any specific engine, rear end, suspension components, etc., of any driver's car may be protested by any driver in that feature after the race for **the amount designated** in terms of cash. All parties concerned shall be bound by decisions rendered by speedway management or tech officials. All measurements will be with Selinsgrove Speedway equipment or authorized agents.

PROTESTED ITEM: The protester may only protest **ONE** specific component

TIME OF THE PROTEST: The protester's written protest clearly state the name of the driver making the protest, the name of the driver being protested and the component they are protesting. The protest must also be signed and dated. The written protest **MUST** be accompanied by a full payment of **\$500.00** in cash and must be presented to the division's tech inspector **NO** later than **fifteen (15) minutes** following the finish of the race. A driver may protest only the driver finishing directly in the position in front of him and on the lead lap. Once a protest is made, it may not be withdrawn. All purse and points are to be distributed after a decision on the protest has been made. Technical inspectors will not accept verbal protests or protests which are not accompanied by the required protest fee.

CHECKING THE PROTEST: After the technical inspector has completed his/her normal post race inspection(s) then and only then will the protest process begin.

Along with tech officials the only persons permitted in the tech area are the driver and one crew member from the car going through the protest tech process. Tech officials may permit a second crew member to assist if they deem it necessary.

THE PROTESTER'S CAR WILL BE CHECKED FIRST FOR THE LEGALITY OF THE SAME COMPONENT FOR WHICH THEY FILED THEIR PROTEST.

WHEN THE PROTESTER'S CAR IS FOUND TO HAVE AN ILLEGAL COMPONENT: After inspection, if the protester's car is found to have an illegal component, the driver of that car will be disqualified from that event, forfeits all prizes and honors earned at the event and face the possibility of more penalties at the discretion of Speedway Management. The illegal parts will also be confiscated by speedway management immediately. The protest money will be forfeited and kept by speedway management for distribution as they see fit.

If a decision at the track cannot be made, then the component will be kept for further testing and validating at the discretion of speedway management until a final decision on legality can be determined. The protested component may be sent to an independent tester at the protester's expense for review.

It is the driver's duty to prove his legality, not the tech officials duty to prove the violation. Only the protested component may result in a disqualification during the protest process – no other components will be considered regardless of their legality.

If the component in question on the protester's car is found to be illegal the car being protested **WILL NOT** be checked.

WHEN THE PROTESTER'S CAR IS FOUND TO HAVE A LEGAL COMPONENT: After inspection, if the protester's car is found to have a legal component, the car being protested will be checked.

REFUSAL OF A PROTEST: If the driver of the protesting car does not allow inspection under these terms, he or she will be disqualified, forfeit the protest fee to speedway management, forfeit all points, purse monies, prizes and awards earned at that event and possibly suffer more penalties as determined by Speedway Management. The car being protested will then NOT be checked.

WHEN THE PROTESTED CAR IS FOUND TO HAVE AN ILLEGAL COMPONENT: After inspection, if the protested component is found illegal, the driver of that car will be disqualified from that event, forfeits all prizes and honors earned at the event and face the possibility of more penalties at the discretion of Speedway Management. The illegal parts will also be confiscated by speedway management immediately. The protest money will be returned to the team filing the protest.

If a decision at the track cannot be made, then the component will be kept for further testing and validating at the discretion of speedway management until a final decision on legality can be determined. The protested component may be sent to an independent tester at the protester's expense for review.

It is the driver's duty to prove his legality, not the tech officials duty to prove the violation. Only the protested component may result in a disqualification during the protest process – no other components will be considered regardless of their legality.

WHEN THE PROTESTED CAR IS FOUND TO HAVE A LEGAL COMPONENT: After inspection, if the protested component is found legal, the protest money will be given to the driver of the car from which the component was protested (less a **\$100.00** inspection fee and shipping charges (if any as determined by Speedway Management)).

REFUSAL OF A PROTEST: If the driver of the protested car does not allow inspection under these terms, he or she will be disqualified, forfeit all points, purse monies, prizes and awards earned at that event and possibly suffer more penalties as determined by Speedway Management.

SCORING PROTESTS: Only the driver or car owner may protest to the scorers and only after all racing is completed for the evening. Scoring protests may be verbal and do not require a protest fee.

DRAWINGS (Attached Below)

- 1 - Top View
- 2 - Side View
- 3 - Spoiler Support
- 4 - Rear Roof Support
- 5 - Quarter panel options

- 1.3a - Roof length must be a minimum of forty-four inches (44") to a maximum of fifty-four inches (54").
- 1.3b - Roof width must be a minimum of forty-eight inches (48") to a maximum of fifty-two inches (52").
- 1.4a - All roof side panels must extend to edge of decking.
- 1.5f - Front fender flares cannot extend beyond front tire more than one inch (1") in width with the wheels pointed straight.
- 1.6a - Door cannot exceed seventy-six inches (76") in it's entirety at top of door.
- 1.6b - Door cannot exceed eighty-two inches (82") in width at the bottom in the center of car.
- 1.7b - The quarter panels cannot exceed seventy-six inches (76") in width at any point behind the center of the rear hub as measured at the top.
- 1.7c - Rear decks must taper from seventy-six inches (76"), as measured at the top over the rear hubs, uniformly back to seventy-two inches (72)" at the spoiler, equally on both sides.
- 1.8b - Maximum spoiler width is seventy-two inches (72").

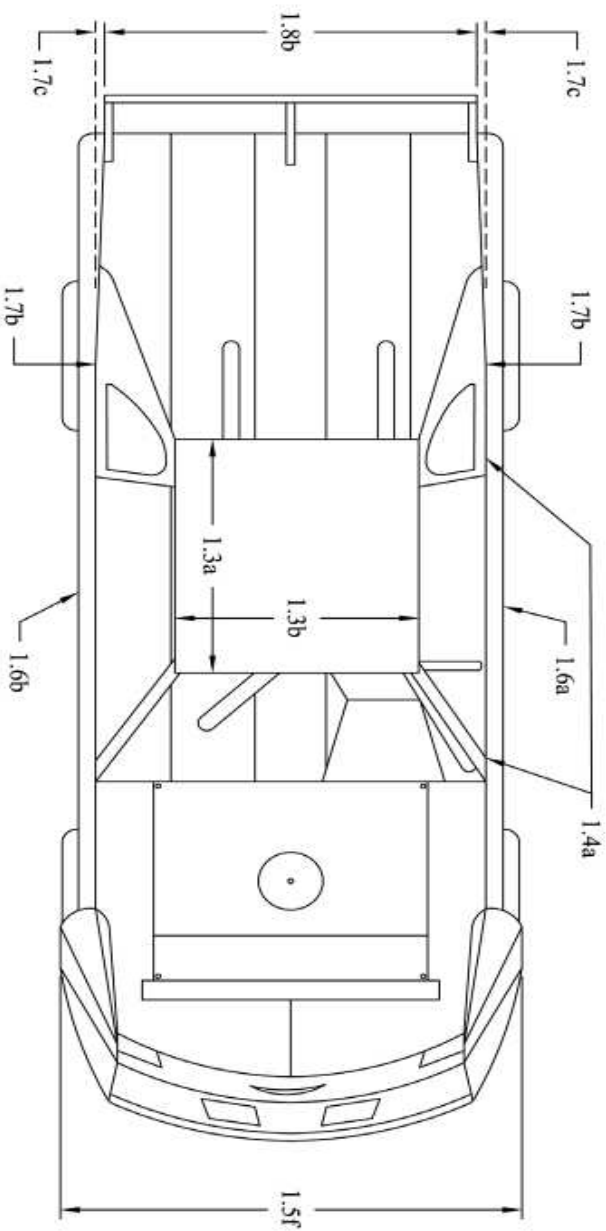

**LATE MODEL
TOP VIEW DIMENSIONS**

- 1.2e - Stock Nosepiece can extend a maximum of fifty-two inches (52") from center of front hub to farthest point extending forward.
- 1.3d - Roof height must be between forty-five (45") and forty-eight inches (48") from the ground.
- 1.5d - Front fenders can not exceed thirty-seven inches (37") in height measured from the ground.
- 1.5g - The front fender flares may not be higher than fenders by more than two inches (2").
- 1.6c - Doors can not exceed thirty-seven inches (37") in height measured from the ground.
- 1.7a - Fifty-two inches (53") maximum center of rear hub to top corner of quarter panel.
- 1.7f - Forty-eight inches (48") maximum length from center of rear hub to end of quarter panel.
- 1.7g - Thirty-eight inches (38") maximum height from top of deck to ground.
- 1.7h - Minimum of two inches (2") tire clearance from body.
- 1.7i - Any skirting can not extend beyond the quarter panel.

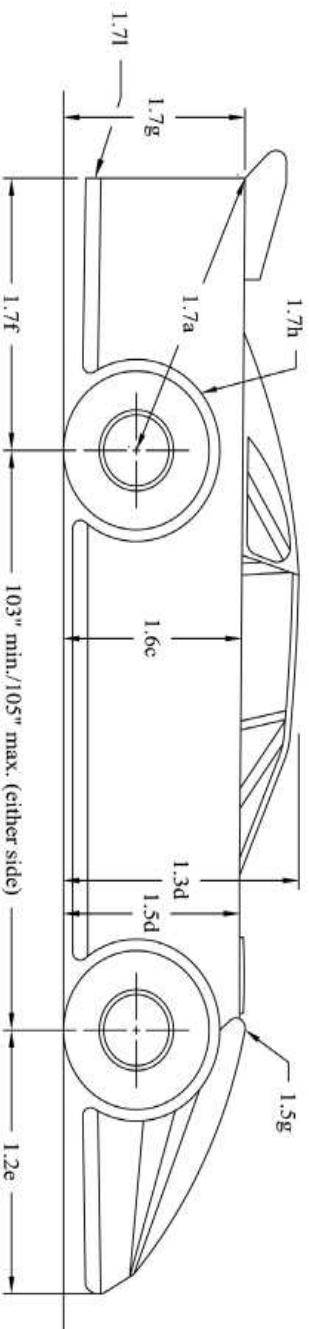

**LATE MODEL
SIDE VIEW DIMENSIONS**

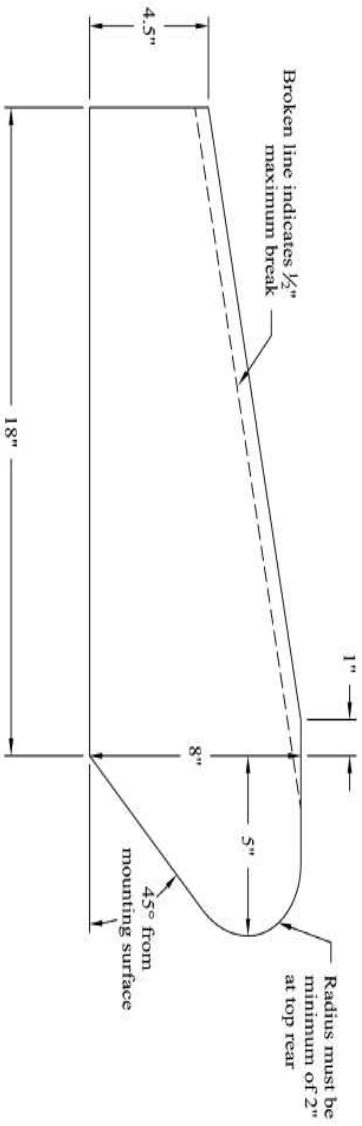

No more than three (3) spoiler supports permitted. Front edge of supports must be in line.

Dimensions Have Zero Tolerance

**DIRT LATE MODEL
SPOILER SUPPORTS**

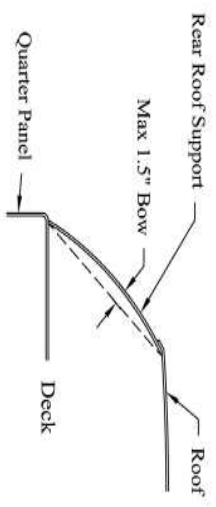

17" Maximum from rear of roof to front of support

REAR VIEW

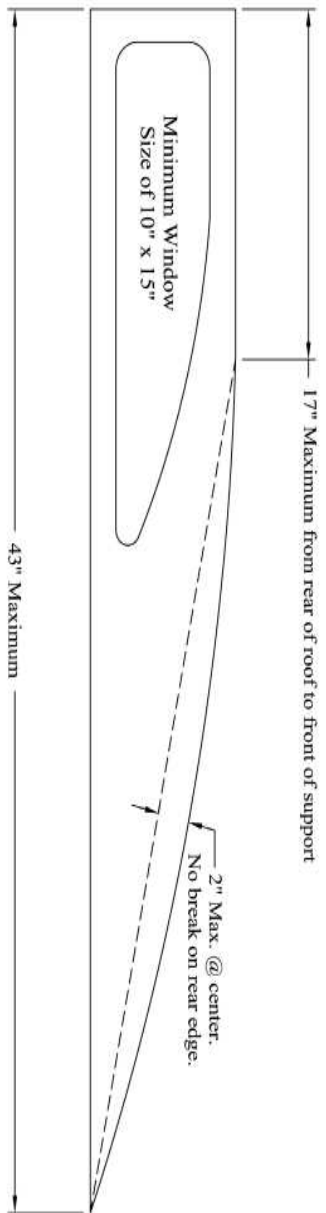

DIRT LATE MODEL
WINDOW SIDE PANEL
& REAR ROOF SUPPORT

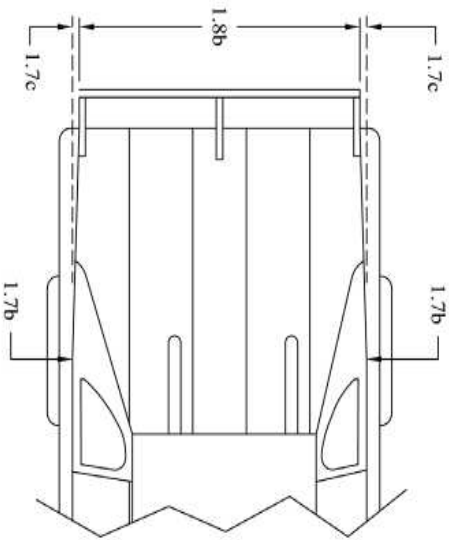

Option 1

Rear decks must taper from seventy-six inches (76"), as measured at the top over the rear hubs, uniformly back to seventy-two inches (72)" at the spoiler, equally on both sides.

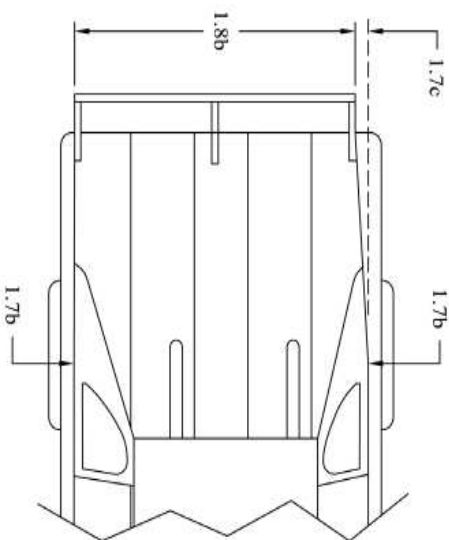

Option 2

Rear decks must taper from seventy-six inches (76"), as measured at the top over the rear hubs, uniformly back to seventy-two inches (72)" at the spoiler, on the left side only.

LATE MODEL REAR QUARTER PANEL OPTIONS